

ALMA Memo No. 284

Optics for the 600-720 GHz Mixer Test Receiver

S. Srikanth and G. A. Ediss
National Radio Astronomy Observatory

January 24, 2000

INTRODUCTION:

The Central Development Laboratory is in the process of designing a 600-720 GHz test receiver for evaluating SIS mixers. This test receiver will have provision for a Martin-Puplett Interferometer (MPI) for LO injection/sideband separation, external to the dewar. As the feed horn will be an integral part of the mixer block at this frequency, the optics for the mixer test receiver are designed to be compatible with the ALMA telescopes and as a possible prototype for the ALMA receivers. Two approaches are considered: refractive optics (using lenses) and reflective optics (using mirrors). Two scenarios for the ALMA receivers are presented: (i) where a MPI is used and (ii) where MPI is not needed. The optics were designed using Gaussian beam mode analysis and then checked by more rigorous analysis. Calculated field patterns are shown. The dimensions of the optics for this band have also been determined.

PARAMETERS FOR ALMA TELESCOPES:

For the ALMA telescopes, an f/D ratio of 8 is assumed. The half angle subtended by the subreflector at the secondary focus is 3.58° . An edge taper of -12 dB is chosen for the subreflector illumination pattern. For these parameters, the beam waist at the secondary focus is 2.7 mm in radius (W_{tel}) at 660 GHz.

REFRACTIVE OPTICS:

It is not desirable to couple the telescope beam to that of the feed horn directly as the feed horn becomes inconveniently large. A moderate size corrugated feed horn with a phase correcting lens is usually used at lower frequencies to produce the required beam waist at the telescope focus. This results in the most compact optics layout in the dewar. The relationship between the focal length, f , of the lens and the beam waist sizes for frequency independent coupling is given by:

$$f = W_f * W_{tel} * \frac{\pi}{\lambda} \quad (1)$$

where λ is the wavelength and W_f is the beam waist radius of the feed horn. Two cases of feed horn/lens combinations were considered for the receiver without a MPI. A corrugated feed horn

with an aperture diameter of 3.9 mm and length of about 17 mm produces a beam waist of 1.05 mm (W_f) at 660 GHz. A suitable lens with a single refracting surface has $f = 19.8$ mm and diameter of 14.4 mm. Using Teflon as the material for the lens, the thickness of the lens is 3.9 mm for room temperature operation. The absorption loss is about 7.5% at room temperature and 4% at 15 K [1], in addition to estimated reflection loss of 3% at each unmatched surface [2]. Anti-reflection grooves are difficult to machine at these frequencies. Using a larger feed horn with aperture diameter of 7 mm and length of 32.9 mm results in a lens with focal length of 30.1 mm and thickness of 2.3 mm. The absorption loss is 4.5% and 2.3% at room temperature and at 15 K, respectively. In both cases, the distance of the lens surface from the aperture of the feed horn is about 11.5 mm. Figure 1 shows the dimensional details for the optics using refractive lenses.

If a MPI is used for LO injection and/or signal/image separation, it needs to be introduced in the optical path where the waist is large and fairly uniform. With the MPI, two lenses will have to be used which doubles the losses. Past experience also suggests unpredictable dielectric properties at these high frequencies.

REFLECTIVE OPTICS:

Off-axis metal mirrors, providing an unblocked aperture along the optical path, are an attractive alternative to the refractive lenses discussed in the previous section. Standard off-axis parabolic mirrors available from Janos Technology, Inc. have been used as the basis for the reflective optics design. For the case with balanced mixers, using a single mirror of effective focal length of 25.4 mm, the telescope beam waist of 2.7 mm is transformed to a beam waist of 1.36 mm at the feed horn. A mirror of 1" projected aperture located at a focal length distance from the feed horn phase center will produce the required beam waist at the telescope secondary focus. For this arrangement, the feed horn phase center needs to be near its aperture and, hence, a spherical phase factor of 0.20λ is chosen. The spherical phase factor Δ is given by:

$$\Delta = \frac{a}{\lambda} * \tan\left(\frac{\theta_0}{2}\right) \quad (2)$$

where a is the aperture radius and θ_0 is the horn semi-flare angle. The beam waist of the feed horn (W_f) is given by:

$$W_f = \frac{0.644 * a}{\{1 + [\pi * (0.644 * a)^2 / (\lambda * R_h)]^2\}^{0.5}} \quad (3)$$

where R_h is the slant length of the feed horn or the radius of curvature of the phase front at the aperture. With $\Delta = 0.20\lambda$ and $W_f = 1.36$ mm, equation (2) and (3) can be solved for a and θ_0 . This

results in an aperture diameter of 4.76 mm and $\theta_0=4.37^\circ$. The phase center of the feed horn is at a distance of 8 mm from the aperture inside the feed horn. Figure 2 shows the feed horn and mirror locations.

For the receiver where a MPI will be used, a large beam waist is required. This waist situated between a pair of off-axis parabolic mirrors can be effectively coupled to the feed horn waist on one side and the telescope waist on the other. The MPI will be conveniently positioned between these mirrors. A distance of 228.6 mm (9") between the mirrors is sufficient for this arrangement. Two off-axis mirrors with 45° angle of incidence and effective focal lengths of 76.2 mm (3") and 152.4 mm (6") were chosen. Tracing backwards from the telescope beam waist of 2.7 mm, the $f = 152.4$ mm mirror will produce an 8.1 mm beam waist. The beam is focused at infinity and, hence, the beam radius remains almost uniform at 8.1 mm between the mirrors. The $f = 76.2$ mm mirror will transform this waist to a waist of 1.36 mm at the feed horn end. Figure 3 shows the layout of the optics with beam waist sizes and locations. This can be folded into a compact arrangement, as shown in Figure 4, to accommodate a MPI for the two polarization channels.

In order to keep diffraction loss at a single aperture to less than 0.5%, the aperture size should be greater than $3.5 W$, where W is the waist of the incident beam. Mirrors with projected aperture diameter of 2" are standard items available from Janos Technology, Inc. and these are substantially larger than required.

ANALYSIS:

Design of reflective optics with Gaussian beam analysis is not accurate for the following reasons: First, when using off-axis parabolic mirrors, the initial circularly symmetric beam from the feed horn becomes weighted towards one side because of the difference in path lengths to the two edges of the mirror in the plane of incidence. Second, the reflective mirror is in the near-field region of the feed horn and, hence, analysis based on geometric optics is not accurate enough. An analysis based on Physical Optics (PO) was carried out to study the effects of asymmetry. While computing currents on the reflector, the incident field is represented by spherical wave expansion (swe) modes in the program. The swe modes are calculated from far-field patterns and the expansion is completely general. This enables calculation of near-field values including radial components of the incident field.

Figure 5 shows the far-field patterns of the feed horn at three frequencies. The reflected far-field patterns at 660 GHz for the single mirror optics are shown in Figure 6. These patterns are incident on the subreflector and the taper at the edge (3.58°) of the subreflector varies between -13.1 dB and -13.9 dB in the 600-720 GHz band. Patterns in the plane of incidence are asymmetric because of the asymmetry in the reflector. For the two-mirror case where a MPI is used, patterns from the first reflector at 660 GHz are shown in Figure 7. These patterns are used as input patterns for the second reflection. Figures 8 and 9 show the far-field patterns from the second reflector in the plane of incidence and in the orthogonal plane, respectively. The patterns

are asymmetric in the plane of incidence. With mirrors of 2" diameter, the two rays to the opposite edges of the mirror in the plane of incidence have a large path length difference. The above analysis was repeated replacing the 2" diameter mirrors with 1.5" diameter mirrors. The output patterns are shown in Figures 10 and 11. The asymmetry in the pattern is less severe compared to the 2.0" diameter mirrors. The total spillover loss in the optics is less than 0.2% for the 2.0" mirrors and less than 0.4% for the 1.5" mirrors. The taper at the edge of the subreflector varies between -10.5 and -16.5 dB and between -13.8 and -17.5 dB for the 2.0" and 1.5" mirrors, respectively. It is proposed to use the 1.5" diameter mirrors.

CONCLUSION:

The use of refractive lenses for the 600-720 GHz band has the disadvantages of losses and unpredictable dielectric properties. Reflective mirrors are practically lossless and can be bought off-the-shelf. The lab receiver will use a single 1.5" diameter mirror inside the dewar with an optional MPI located outside the dewar. The ALMA receiver without a MPI can use the 1" diameter mirror ($f = 25.4$ mm) to match to the telescope waist. The optics, including a beam splitter and feeds for the two polarizations, will require a volume of 4" x 2.5" x 1.5" with 4" along the lateral direction and 2.5" along the feed axis. If a MPI is required, the optics using the 1.5" diameter mirrors will require a volume of 8" x 11" x 2" for the two polarizations.

REFERENCES:

- [1] J. W. Lamb, "Miscellaneous Data on Materials for Millimetre and Submillimetre Optics," *International Journal of Infrared and Millimeter Waves*, vol. 17, no. 12, pp. 1997-2034, Dec. 1996.
- [2] P. F. Goldsmith, *Quasioptical Systems: Gaussian Beam Quasioptical Propagation and Applications*, Piscataway, NJ, IEEE Press, 1998.

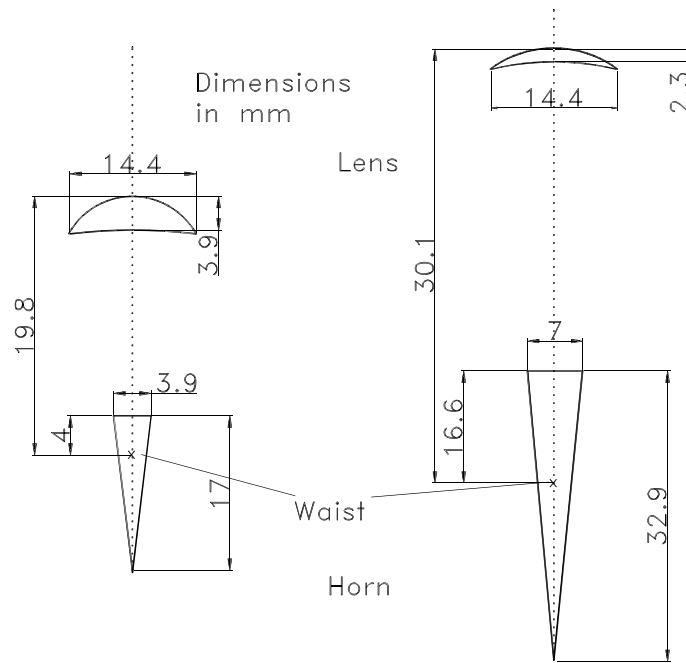

Fig. 1. Refractive optics layout.

Dimensions
in mm

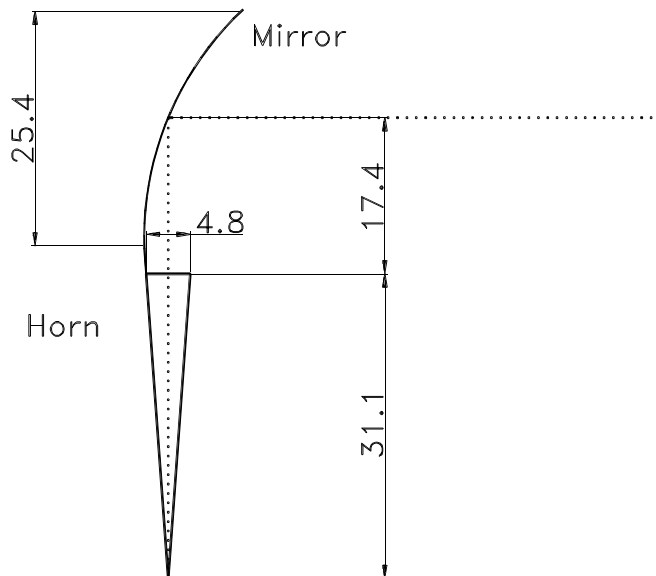

Fig. 2. Reflective optics layout using balanced mixers.

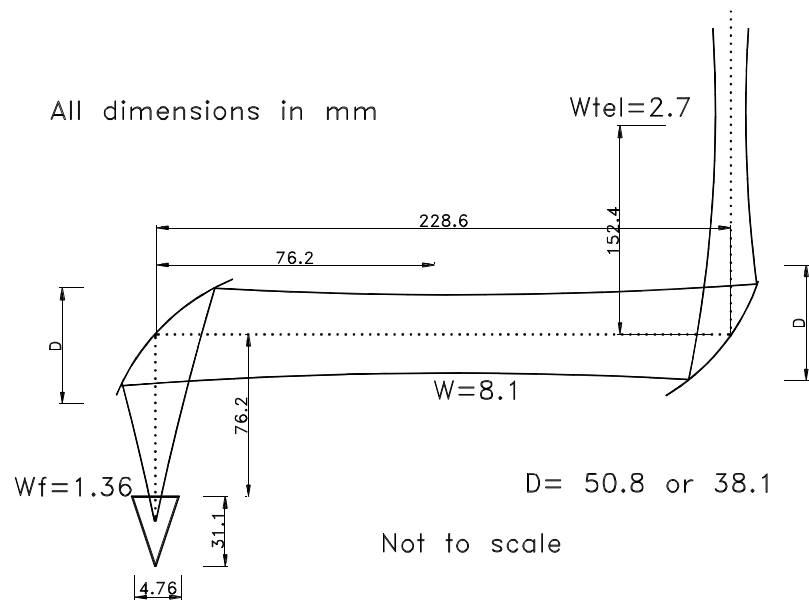

Fig. 3. Reflective optics layout to accommodate MPI.

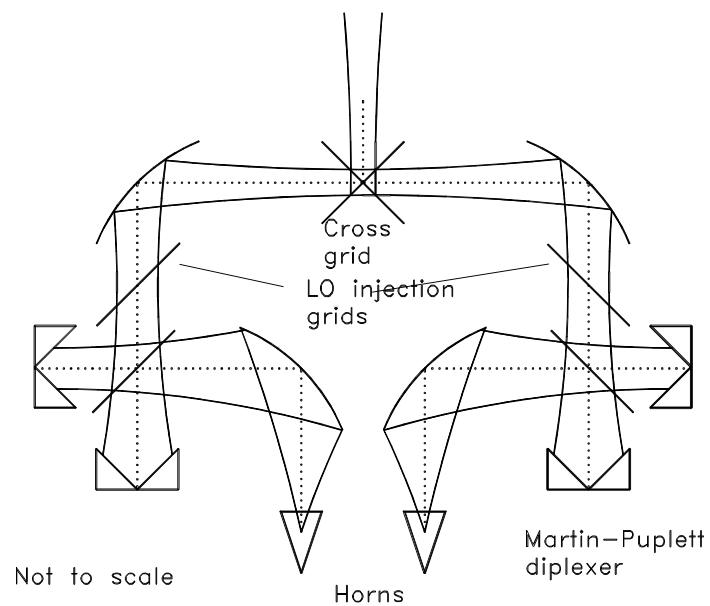
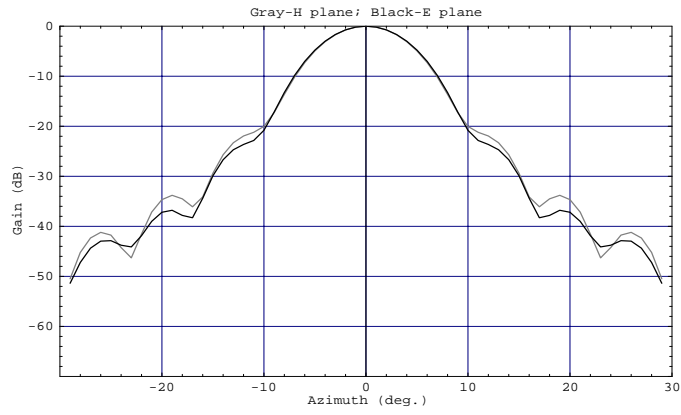
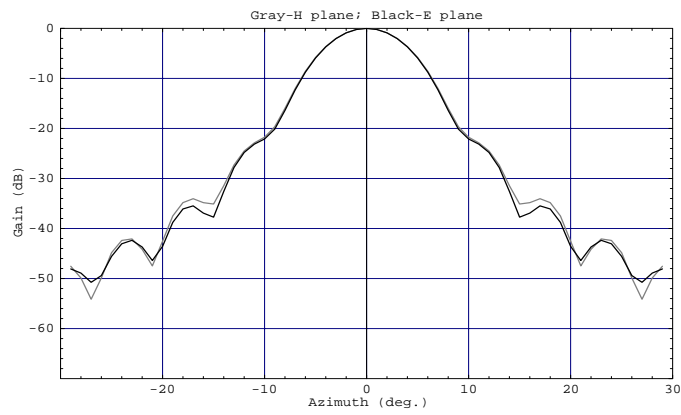

Fig. 4. Reflective optics layout with MPI for the two polarizations.



(a) 600 GHz



(b) 660 GHz

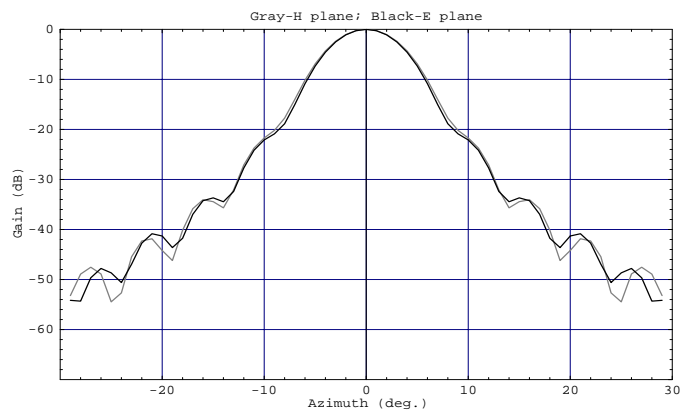

(c) 720 GHz

Fig. 5. Far-field patterns of feed horn.

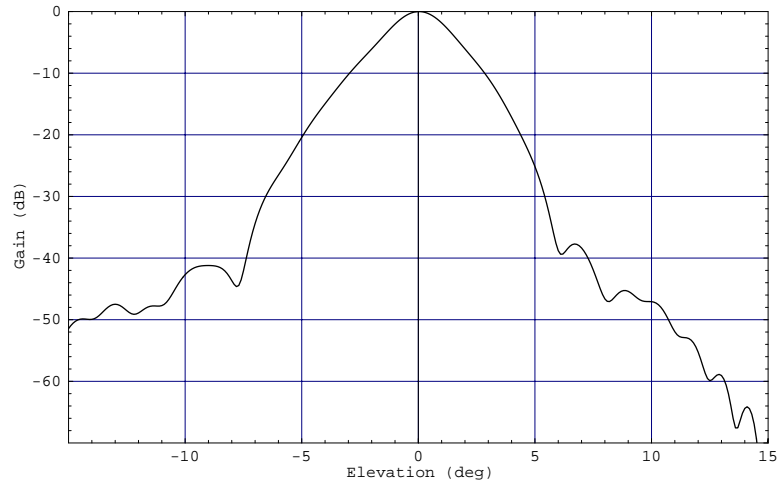

(a) Plane of incidence

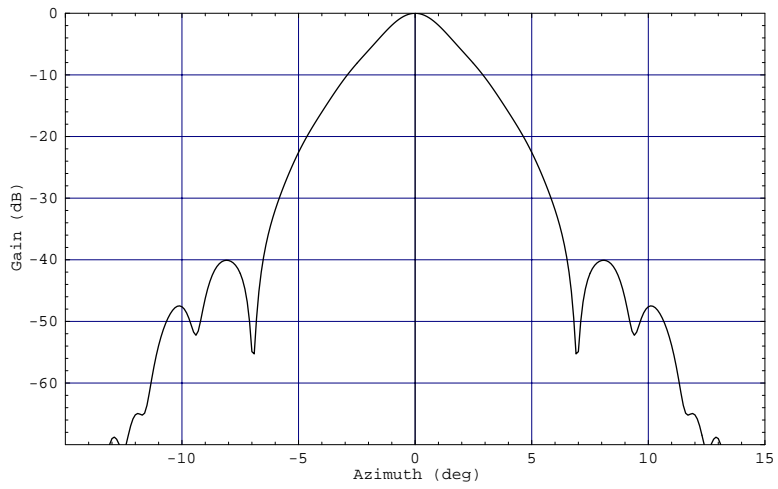

(b) Asymmetric plane

Fig. 6. Far-field patterns of reflective optics without MPI.

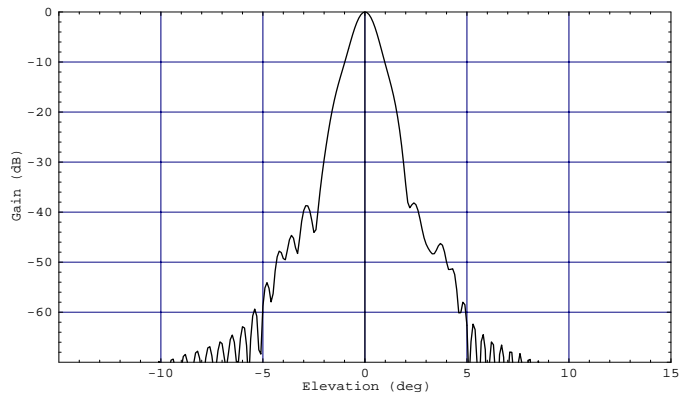

(a) Plane of incidence

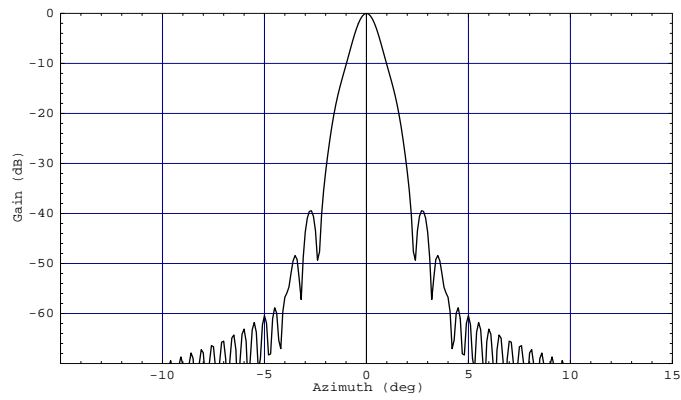

(b) Asymmetric plane

Fig. 7. Far-field patterns of first reflector (2.0") at 660 GHz.

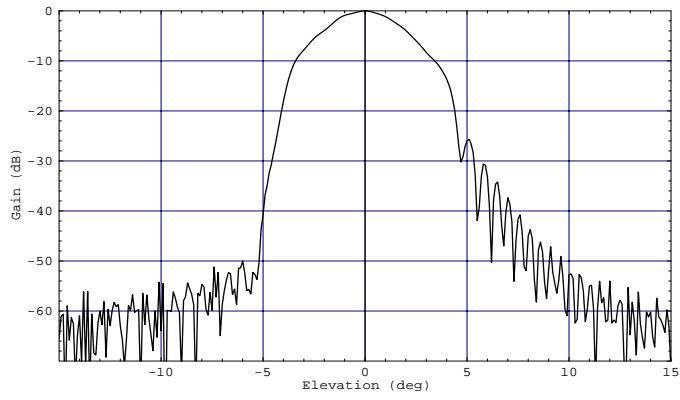

(a) 600 GHz

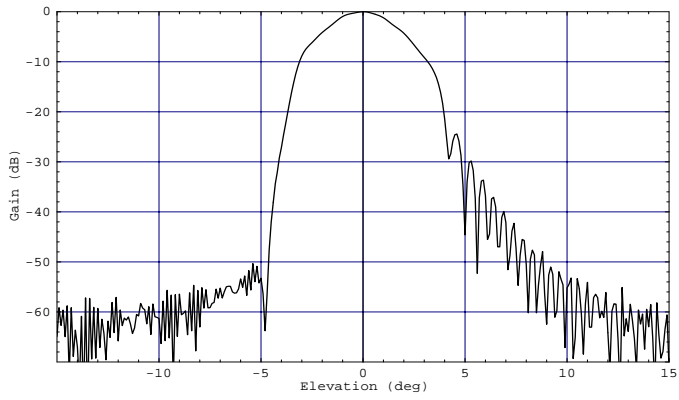

(b) 660 GHz

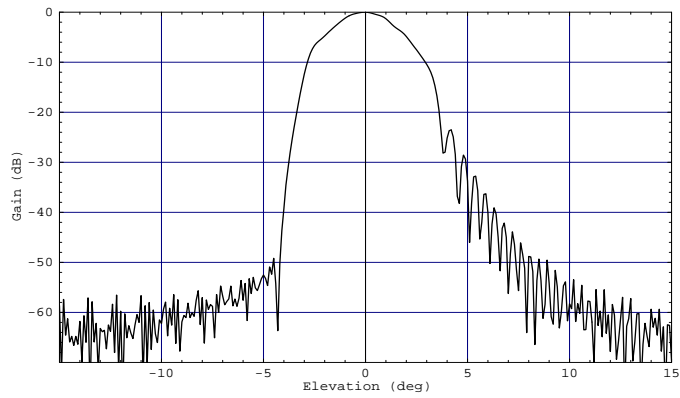

(c) 720 GHz

Fig. 8. Far-field patterns of second reflector (2.0") in the plane of incidence.

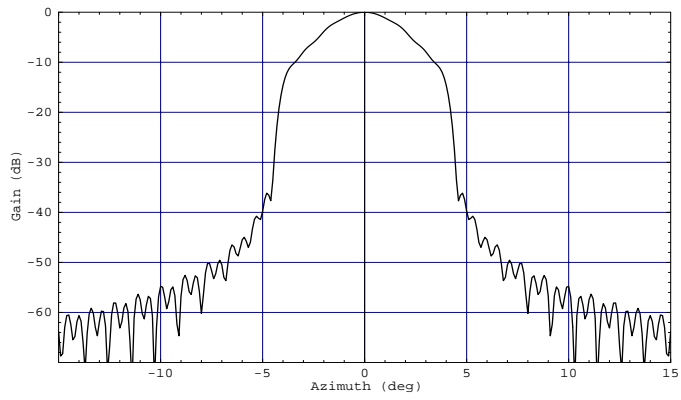

(a) 600 GHz

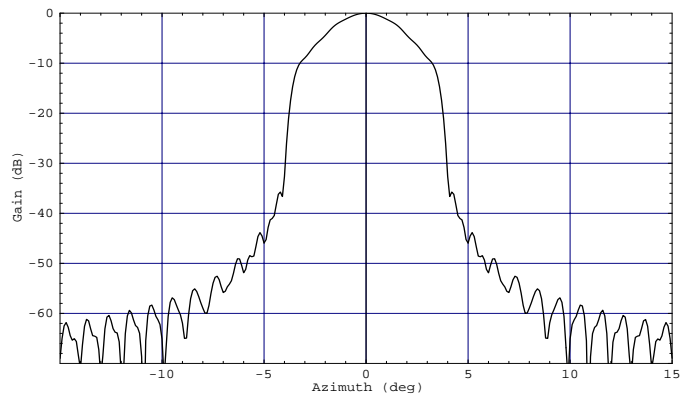

(b) 660 GHz

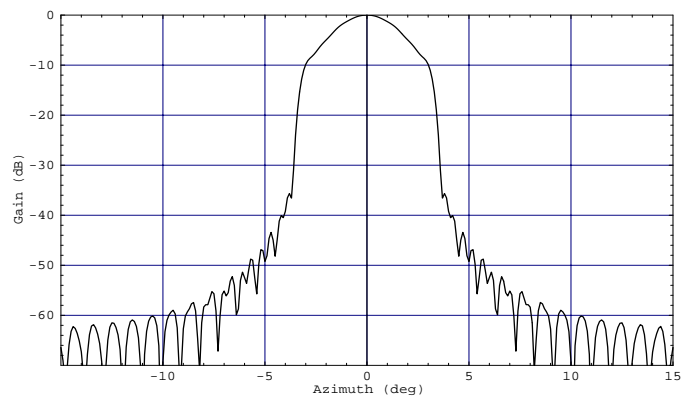

(c) 720 GHz

Fig. 9. Far-field patterns of second reflector (2.0") in the asymmetric plane.

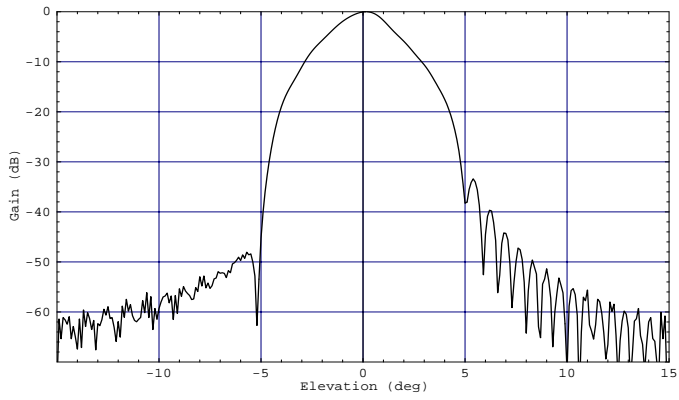

(a) 600 GHz

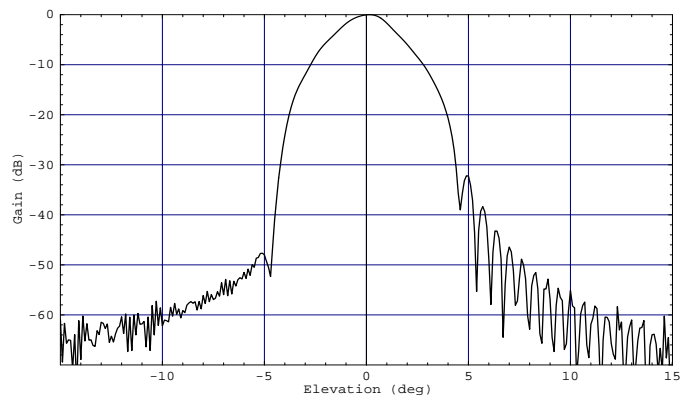

(b) 660 GHz

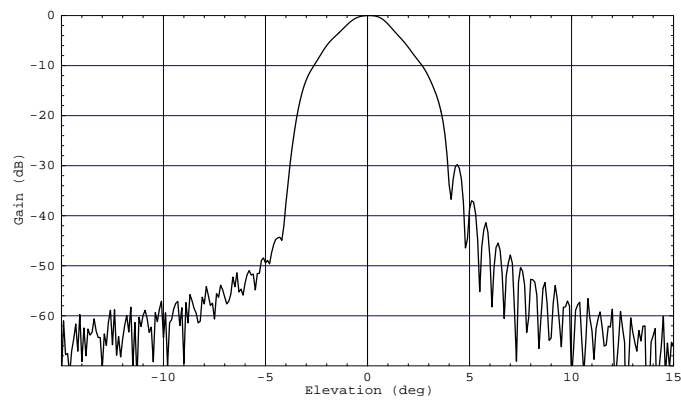

(c) 720 GHz

Fig. 10. Far-field patterns of second reflector (1.5") in the plane of incidence.

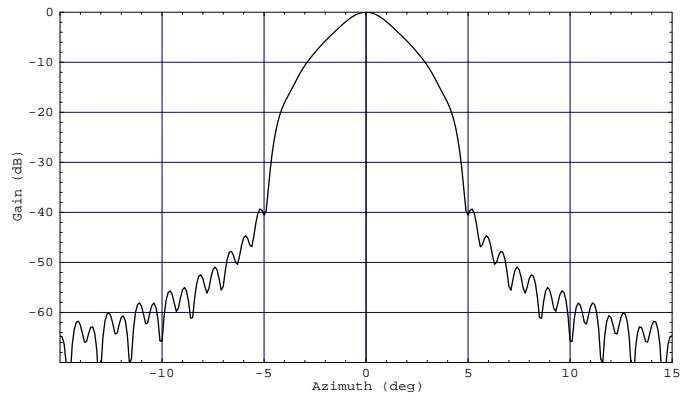

(a) 600 GHz

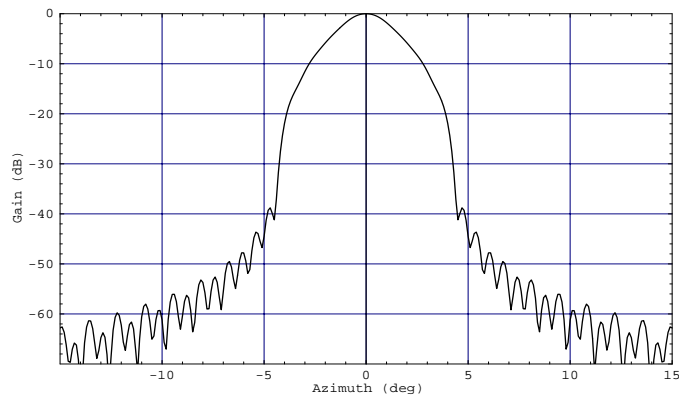

(b) 660 GHz

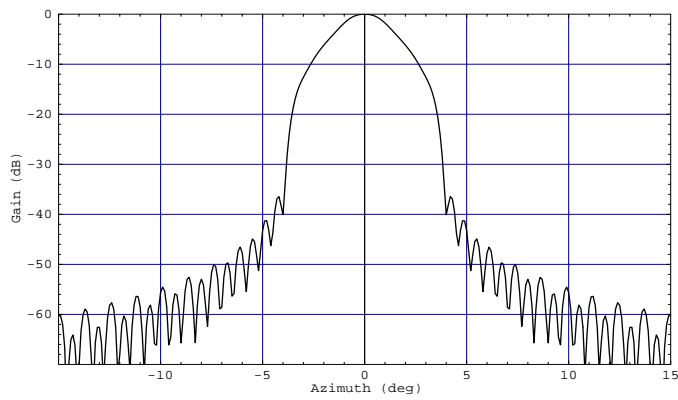

(c) 720 GHz

Fig. 11. Far-field patterns of second reflector (1.5") in the asymmetric plane.